

Benefits

The McMag²⁰⁰⁰ provides farmers and irrigators an affordable and easy-to-read mag with minimal maintenance and little to no downtime. As the only mag meter on the market with a price tag comparable to a propeller meter, the McMag²⁰⁰⁰ has a low cost of ownership without compromising durability and accuracy. The McMag²⁰⁰⁰ is portable, making it an efficient purchase for users with multiple irrigation lines. This mag's familiar saddle-style form and streamlined functionality allows for in-field programmability and serviceability, guaranteeing minimal downtime and maximum control. It's the hassle-free, wallet-friendly, works-when-you-need-it-to, simple to use, mag meter, only from McCrometer.

Designed for Accuracy, Built to Last

- Durable, built with a time-tested rugged design
- Consistent and repeatable measurements
- Versatile, with a wide range of applications

Installation

The McMag²⁰⁰⁰ offers hassle-free installation, even in tight spaces. No flanges or costly welding is involved. Users simply cut a 3" diameter hole in the top of their pipe and slide the sensor into the hole, and then cinch the meter onto the pipe using the Factory provided U-straps.

The meter can be mounted in a horizontal or vertical position with a full pipe of water. A minimum of five pipe diameters upstream of a flow disturber and two pipe diameters downstream from the meter are required to ensure optimal accuracy of $\pm 2\%$. When used with a flow straightener, these distances are 1.5 diameters upstream and 1 diameter downstream.

Existing saddle style Mc Propeller meters can be easily and quickly retrofit to the Mc Mag²⁰⁰⁰ in the field.



KEY FEATURES

- $\pm 2\%$ accuracy
- Easy in-field installation
- Low maintenance
- 5-year full warranty
- Low cost of ownership
- "Do-it-yourself" programmability
- Minimal pipeline intrusion

APPLICATIONS

- Center Pivot Systems
- Well Monitoring
- Water Distribution
- Chemigation
- Livestock Waste Lagoons
- Surface Water
- Golf Courses and Park Management

Description

The McMag²⁰⁰⁰™ provides growers and irrigators with a new alternative for flow measurement. With a 5-year meter warranty, a 5-year battery life, and saddle mount design, the McMag²⁰⁰⁰ delivers the dependability and ease-of-installation McCrometer has provided to the agricultural market for over 65 years. The electromagnetic sensor offers accuracy as good as $\pm 2\%$.

The meter is available to fit a common range of agricultural line sizes, from 4" to 16" diameter pipe or tube.

The innovative design of the McMag²⁰⁰⁰ saddle mount meter offers modular design to ensure McMag²⁰⁰⁰ continues to have low cost of ownership, the main components can be easily and affordably updated in field without downtime.

The meter combines a saddle, precision sensor, and a battery powered integrated electronic converter package to provide accurate flow measurement for full-pipe flow monitoring applications.

The integrated electronic converter is secured with tamper resistant screws to protect against unauthorized access. The meter offers flow rate and total water used and a 5-year warranty. The McMag²⁰⁰⁰ features two 3.6V lithium-thionyl chloride (Li-SOCl₂) D size batteries, and a back-up battery pack. The main power batteries are easily replaced in the field. Pulse output is available for remote meter reading or SCADA.

Pipe Run Requirements

Both upstream and downstream distances are measured from the center of the sensor as shown at right. In a typical installation to achieve $\pm 2\%$ accuracy the McMag²⁰⁰⁰ flow meter should be installed a minimum of five diameters upstream from most flow disturbers and two diameters downstream of the meter, or when used with a flow straightener, 1.5 diameters upstream and 1 diameter downstream.

Configuration	A	B
With or without straightening vanes	5	2
With flow straightener	1.5	1

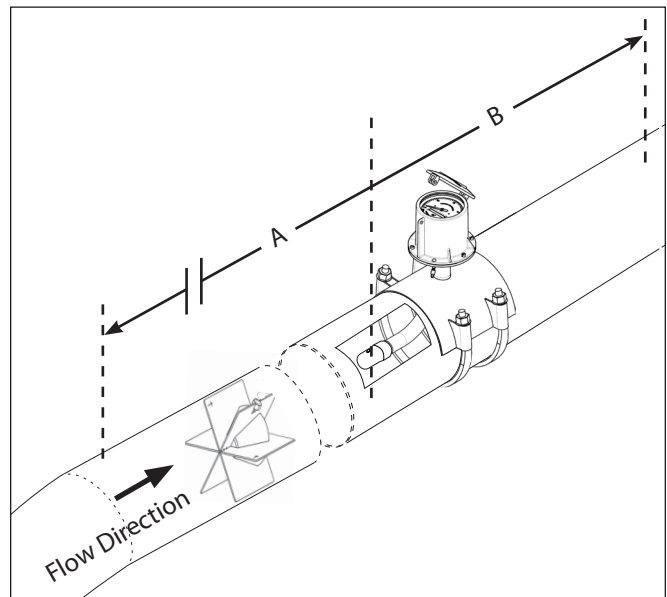

Part Number Structure

G20	-	-	-	-	-
METER SIZE					
4" Saddle Meter	04				
6" Saddle Meter	06				
8" Saddle Meter	08				
10" Saddle Meter	10				
12" Saddle Meter	12				
14" Saddle Meter	14				
16" Saddle Meter	16				
MATING PIPE OR TUBE OPTIONS					
Tube Style Saddle (Nominal Inch OD)	T				
Pipe Style Saddle (Nominal Pipe OD)	P				
Non Standard OD Style Saddle (In available Sizes)	S				
No Saddle (Electronics and Sensor Kit, MC Only)	K				
POWER & OUTPUT OPTIONS					
Battery Power / No Outputs (<i>Default</i>)	-				
Battery Power / Pulse Output	1				
DC Power (10-32v) Battery Backup / Pulse Output	2				
Battery Power / Telemetry Ready Pulse Output (7 pin telemetry cable)	3				
Battery Power / ATT Wireless Telemetry System (RTU, Solar Panel, 7 pin cable)	4				
Battery Power / Verizon Wireless Telemetry System (RTU, Solar Panel, 7 pin cable)	5				
CABLE LENGTH OPTIONS					
6 ft Open end two wire cable (*1,2 power options)	1				
25 ft Open end two wire cable (*1,2 power options)	2				
50 ft Open end two wire cable (*1,2 power options)	3				
6 ft 7 Pin Male telemetry Cable (*3,4,5 Output options)	4				
25 ft 7 Pin Male telemetry Cable (*3,4,5 Output options)	5				
50 ft 7 Pin Male telemetry Cable (*3,4,5 Output options)	6				
6 ft 7 Pin Female telemetry Cable (*3,4,5 Output options)	7				
SADDLE OPTIONS					
F Style Saddles for FS Flow Straightener	F				

Flow Meter Specifications

Description and Operating Specifications

	Volumetric flow in filled flow conduits 4" to 16" utilizing saddle installed sensor. Flow indication in English Standard or Metric units.	
Method	Electromagnetic	
Pipe Sizes and Flow Rates	4"	20 - 600 gpm
	6"	45 - 1350 gpm
	8"	75 - 2350 gpm
	10"	125 - 3700 gpm
	12"	175 - 5300 gpm
	14"	225 - 6700 gpm
	16"	300 - 8800 gpm
Body Style	Saddle mount	
Pressure	150 psi (10.3 bar) working pressure	
Accuracy	±2% accuracy, or ±0.25% of standard full scale flow	
Velocity Range	0.5 ft/s to 15 ft/s	
Empty Pipe Detection	Hardware/Software, conductivity-based	
Electrical Connections	Optional shielded cable for 10-35VDC	
	Optional shielded cable for pulse out	
Pipe Run Requirements	With or without vanes:	5D upstream / 2D downstream
	With flow straightener:	1.5D upstream / 1 downstream
Retrofit	Available using McPropeller saddle	

Display and Measurement

Display	<ul style="list-style-type: none"> • Large LCD display (no backlight) • Non-volatile memory • Anti-reverse totalizer (standard) • Total (to 9 digits of precision) • Flow Rate and Velocity (to 5 digits of precision) • Low battery and empty pipe indication • Opening lid activates display 			
	Digits	5 Rate, 9 Total		
	Rate Units	Gallons per minute	Imperial gallons per minute	Cubic feet per minute
		Million gallons per day	Miner's inch (9G)	Barrels per minute (55G)
		Cubic feet per second	Miner's inch (11.22G)	Barrels per hour (55G)
		Megaliters per day	Acre-feet per day	Barrels per day (55G)
		Liters per second	Kiloliters per hour	Barrels per minute (42G)
Cubic meters per hour		Liters per hour	Barrels per hour (42G)	
Liters per minute		Cubic meters per minute	Barrels per day (42G)	
Gallons per hour				
Totalizer Units	Gallons	Barrel (31G)	Miners Inch Minute (11.22G)	
	Cubic Feet	Barrel (42G)	Miners Inch Minute (9G)	
	Acre Feet	Barrel (46G)	Miners Inch Hour (11.22G)	
	Cubic Meters	Barrel (55G)	Miners Inch Day (11.22G)	
	Liters	Imperial Gallon	Miners Inch Hour (9G)	
	Megaliter	Acre Inch	Miners Inch Day (9G)	
	Metric Ton (KL)	Ton (Short)		

Flow Meter Specifications

Power

Battery	Standard: two 3.6V lithium-thionyl chloride (Li-SOCl ₂) D size batteries. Batteries are field replaceable. Unit contains backup battery.
DC Power	Linear power supply 10-35VDC, 2W
Battery Life	Five-year expected battery life, five-year battery warranty. <i>Note: Battery expectancy is with standard configuration</i>

Environmental

Operating Temperature	10° to 140°F (-12° to 60°C) sensor
Storage Temperature	-40° to 149°F (-40° to 65°C)
Operating Pressure	150 PSI
Water Impermeability	IP67

Outputs

Pulse Output	One digital pulse (open collector) output for volumetric
	With battery power: Maximum allowable is 1 pulse per second, 1 Hz Calculation: Max flow [gpm] / 60 = minimum gallons per pulse
	With DC power: Maximum allowable is 5 pulses per second, 5 Hz Calculation: Max flow [gpm] / 300 = minimum gallons per pulse

Options and Accessories

- Epoxy coated carbon steel flanged spool piece
- DC power w/battery backup
- Annual verification / calibration
- Stainless Steel ID tag
- Boot cover

Materials

Sensor Body	HDPE plastic
Electrodes	Stainless steel (316)
Saddle Mount	Stainless steel (304)
U-Bolt/Hardware	Zinc coated steel
Electronic Housing	IP-67 Certified diecast aluminum, powder coated enclosure w/ tamper resistant seal, 6" x 6" x 5" tall
Saddle Gasket	Neoprene
Boot Cover	EPDM rubber optional

Warranty

Meter	5-year standard warranty
Battery	5-year warranty

Dimensions and Weights

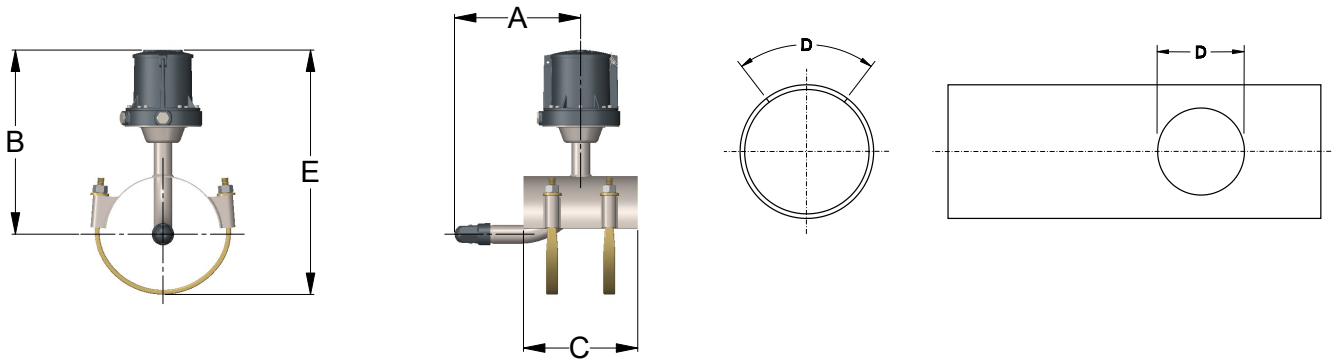

DIMENSIONS							
Meter and Nominal Pipe Size	4	6	8	10	12	14	16
Minimum Flow U.S. GPM	20	45	75	125	175	225	300
Maximum Flow U.S. GPM	600	1350	2350	3700	5300	6700	8800
Approx. Shipping Weight-lbs.	13	15	18	20	24	28	31
A (inches)	5 1/2	9	9	9	9	9	9
B (inches)	10 3/4	13 1/4	13 1/4	13 1/4	14 1/4	16 1/4	16 1/4
C (inches)	7	8	8	9 1/2	9 1/2	9 1/2	9 1/2
D (inches)	3	3	3	3	3	3	3
E (inches)	13 1/4	16 1/2	17 1/2	19 1/2	21 1/2	23 1/2	25 1/2

REQUIRED ORDERING INFORMATION: Pipe O.D. and I.D. are required for all saddle meter orders.